

No. 774,366.

PATENTED NOV. 8, 1904.

Z. J. QUINN.
CASTER.

APPLICATION FILED MAY 3, 1904.

NO MODEL.

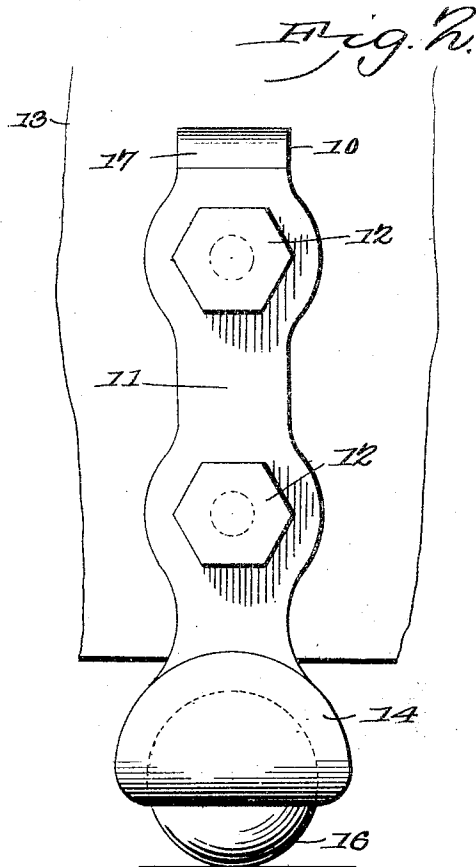
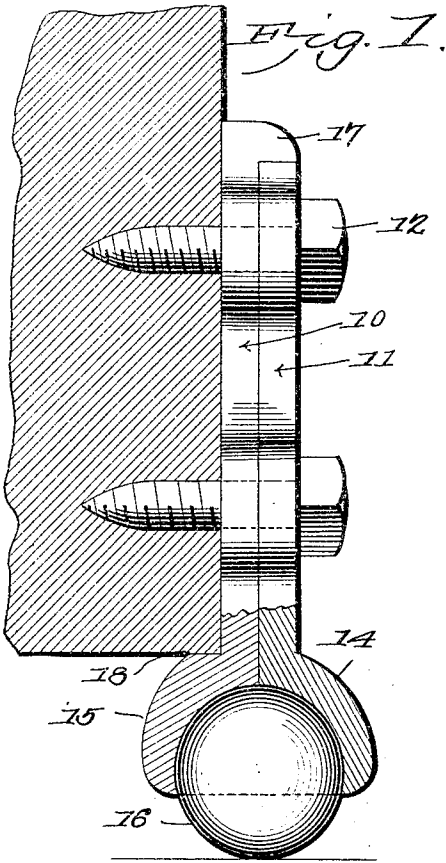

Witnesses
E. H. Stewart
C. N. Woodward

Zenas J. Quinn,
Inventor,
by *C. A. Snow & Co.,*
Attorneys

UNITED STATES PATENT OFFICE.

ZENAS JAMES QUINN, OF THARON, NORTH CAROLINA.

CASTER.

SPECIFICATION forming part of Letters Patent No. 774,366, dated November 8, 1904.

Application filed May 3, 1904. Serial No. 206,233. (No model.)

To all whom it may concern:

Be it known that I, ZENAS JAMES QUINN, a citizen of the United States, residing at Tharon, in the county of Duplin and State of North Carolina, have invented a new and useful Caster, of which the following is a specification.

This invention relates to casters employed upon furniture and similar structures, and has for its object to improve the construction and produce a device of this character which may be inexpensively manufactured, will be strong and durable, easily applied and operated, and by means of which the friction will be materially reduced, and the wear and tear correspondingly reduced.

With these and other objects in view, which will appear as the nature of the invention is better understood, the same consists in certain novel features of construction, as herein after fully described and claimed.

In the accompanying drawings, forming a part of this specification, and in which corresponding parts are denoted by like designating characters, is illustrated the preferred form of the embodiment of the invention, capable of carrying the same into practical operation, and it being understood that the invention is not necessarily limited thereto, as various changes in the shape, proportions, and general assemblage of the parts may be resorted to without departing from the principle of the invention or sacrificing any of its advantages, and the right is therefore reserved of making all the changes and modifications which fairly fall within the scope of the invention and the claims made therefor.

In the drawings thus employed, Figure 1 is a side elevation, partially in section, and Fig. 2 is a front elevation, of the improved device.

The improved device comprises two plates 10 11, placed face to face and provided with one or more sets of transversely-aligned apertures for receiving the holding-bolts 12, by which the plates are secured to the supporting structure 13, which may be any piece of furniture to which the device is applicable. In their lower ends the plates 10 11 are formed

with semispherical socket members 14 15, which when united form an approximately globular socket open at its lower end for supporting a spherical or globular caster-wheel 16 and preventing it from dropping out after the plates are united. In practice about three-fifths of the ball-caster will be covered by the socket members, leaving two-fifths exposed for contact with the floor; but these proportions of course may be varied, if required.

The plate 10 may be provided with a rib 17 overhanging the plate 11 to relieve the bolts 12 from the upward thrust or strain, and the plate 10 may also be formed with a shoulder 18 to bear against the structure 13 for the same purpose.

By this simple structure it is obvious that a very strong and durable device is produced, easily applied and operated, and which may be employed upon various forms and styles of furniture and other structures requiring the same.

The device may also be employed upon safes and other similar and analogous structures.

Having thus described the invention, what is claimed is—

The herein-described improved caster comprising two plates having transversely-aligned bolt-apertures and provided at one end with oppositely-disposed recesses combining to form an approximately globular socket, one of said plates being provided at its upper end with a lip overhanging the other plate and one of said plates being also provided with a shouldered offset, a ball seated in the globular socket and protruding at the lower end thereof, and bolts connecting the plates with each other and with the member to be supported by the caster.

In testimony that I claim the foregoing as my own I have hereto affixed my signature in the presence of two witnesses.

ZENAS JAMES QUINN.

Witnesses:

F. D. McCALEB,
W. M. BISHOP.